

RK467 G7

Rail King[®]
MOBILE RAILCAR MOVER

**Up to 62,800 lbs
Tractive Effort**



Standard Equipment

Cab Self-contained operator command pod with easy reach controls. Two passenger jump seats. Pressurized, air conditioning and heating systems.

Windows Tinted windows, canted on front.

Lights LED light package with 4 strobe lights.

Air 125 cfm total dual air compressors. Train air charge flow meter.

Cameras Live-view 360-degree camera system.

Design Features

- Volvo 7.7L Tier 4F-320bhp
- Funk DF250 Four-speed automatic transmission
- Meritor planetary rail axles
- Cushion coupler system
- Friction road wheel drive
- Full-width integral bumpers to protect powertrain
- Fabricated steel couplers
- Ergonomically designed full-width cab layout
- Unsurpassed operator visibility
- Easy to use push button controls with color LCD display
- Unlimited access for service — platform lift system

Unrivaled Service Access

The entire platform and cab assembly is mounted on 4 hydraulic cylinders that can raise the assembly up for an additional 18" clearance for access to the entire powertrain. Safety lockouts are standard and remote mounted filters are located for easy and quick services.

**Innovative
weight
transfer
system**



**Self-
contained
operator
command
pod**



**Unrivaled
service
access**



RK467 G7

SPECIFICATIONS

Weight	90,500 lb	41,050 kg
Length	245"	622.3 cm
Width	126"	320.0 cm
Height (on road)	158"	401.3 cm
Height (on rail)	141"	358.1 cm
Rail Clearance	4.5"	11.4 cm
Road Clearance	14.5"	36.8 cm
Speeds (Fwd & Rev)	4	
On road, top speed	10 mph	16 km/h
On rail, top speed	13.5 mph	22 km/h

ENGINE

Make	Volvo
Model	TAD873VE 7.7L
Type	Electronic, 4-cycle, turbocharged diesel
Rated Power	320 bhp (235 kW) @ 2,200 rpm
Fuel Tank	100 gal (378 liters)
DEF Tank	10 gal (38 liters)
Features	US EPA Tier 4(f) (EU Stage IV) compliant
Voltage	24v

MAXIMUM TRACTIVE EFFORT

When both couplers are used	62,800 lb
When one coupler is used	46,360 lb

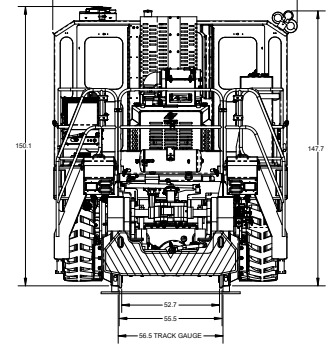
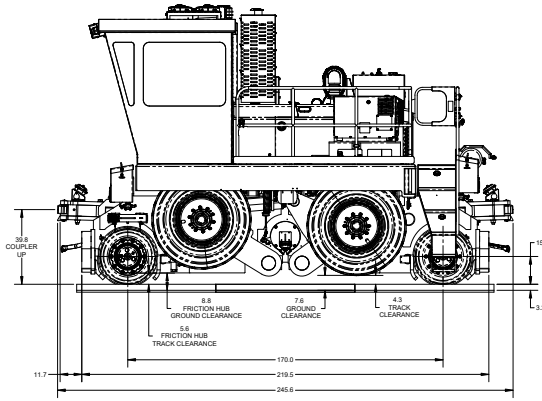

Frame Heavy-duty one-piece unitized frame welded from 3" steel plate.

Engine Powered by the industrial off-road Volvo TAD873VE, inline 6-cylinder 7.7-liter Tier 4 final engine with fully integrated and reliable exhaust aftertreatment system.

Transmission Funk DF250 Powershift with torque converter. Four speeds forward and reverse; operator-controlled automatic or manual shift selection. Also, start in second gear feature.

Rail & Road-Drive Axles Meritor PRC1735 Series heavy duty high torque, outboard planetary axles. Features driver controlled differential lock. Friction road wheel drive transmitted from rail axle incorporates separate braking system. Does not require special tires. Rail shock absorption system with easily replaceable suspension elements is standard.

Wheels

Rail: 30" diameter heat-treated cast steel.

Road: 14.00-24, 28 ply heavy duty rock lug industrial pneumatic tires.

Brakes

Rail Wheel Axles: Outboard dry-disk brakes.

Road Wheel: disc and caliper, hydraulic actuated on steer axle.

Train Air Brakes: Push button operated to release or fully apply, modulating valve for controlled apply or release, and train air hold feature are standard.

Parking Brake: Enclosed spring applies hydraulically released driveline brake.

Pneumatic System High-capacity 125 cfm air compressor system.

Couplers Two weight-transfer couplers made from fabricated steel (no castings).

Sanders Large capacity, replaceable steel sandboxes and eight air-operated sanding tubes. Easy clean receivers: two for each rail wheel, front and back.

Full-Width Cab Standard equipment includes new operator self-contained control pod.

Controls Single hand joystick controls and full color touchscreen LCD display, multi-color LED rocker switch panels.

Other Features Air blast 3 trumpet horn, full LED light package, including 4 strobe lights, and Live-View 360-degree 6 camera safety monitoring system with separate monitors in cab.

Contact Us Today!
281-345-5110

Rail King Headquarters
10750 Telge Road | Houston, TX 77095
sales@railking.net | www.railking.net



Scan for
more info

