

10750 Telge Road · Houston, TX 77095 · Phone: 281-345-5110



RK460

Provides up to 62,700 pounds of tractive effort.



Design Features

- Volvo 7.7L Tier 4 final engine
- Funk DF250 four-speed automatic transmission
- Meritor planetary rail axles
- Royalglide operator comfort system
- Patented cushion coupler system
- Friction road wheel drive
- Full-width integral bumpers to protect powertrain
- Fabricated steel couplers
- Ergonomically designed full width cab layout
- Unsurpassed operator visibility
- Easy to use push button controls with color LCD display
- Unlimited access for service — platform lift system

Standard Equipment

- Self-contained operator command pod with easy to reach controls
- Heavy duty cab air conditioning and heating systems
- Pressurized cab
- Tinted windows, canted on front
- LED light package
- 4 Strobe lights
- 125 cfm total dual air compressors
- Train air charge flow meter
- Live-view 360-degree camera system
- Easy access angled boarding stairs
- 2 Passenger jump seats



Other options available upon request

See reverse for more details

RAIL KING MODEL RK460 MOBILE RAILCAR MOVER

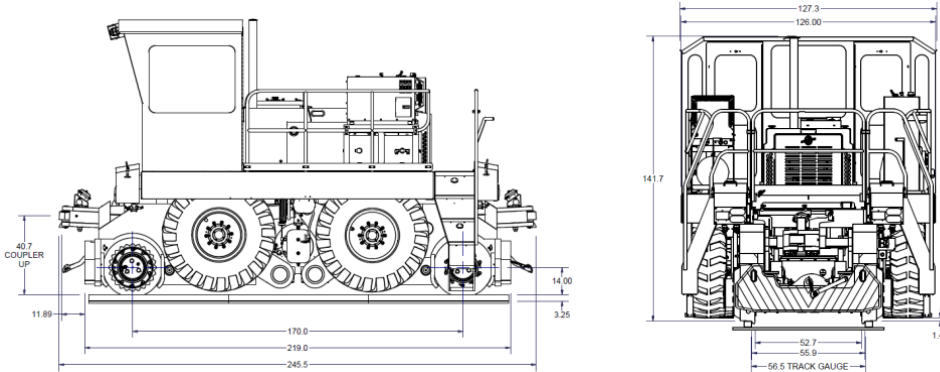

SPECIFICATIONS	
Weight	90,500 lb 41,050 kg
Length	245" 622.3 cm
Width	126" 320.0 cm
Height (on road)	158" 401.3 cm
Height (on rail)	141" 358.1 cm
Rail Clearance	4.5" 11.4 cm
Road Clearance	14.5" 36.8 cm
Speeds (Forward & Reverse)	4
On road, top speed	10 mph 16 km/h
On rail, top speed	13.5 mph 22 km/h

ENGINE	
Make	Volvo
Model	TAD873VE 7.7L
Type	Electronic, 4-cycle, turbocharged diesel
Rated Power	320 bhp (235 kW) @ 2,200 rpm
Fuel Tank	100 gal (378 liters)
DEF Tank	10 gal (38 liters)
Features	US EPA Tier 4(f) (EU Stage IV) compliant
Voltage	24v

MAXIMUM TRACTIVE EFFORT	
When both couplers are used	62,700 lbs.
When one coupler is used	46,200 lbs.

Contact Us Today!

Rail King Headquarters

10750 Telge Road
Houston, TX 77095
Phone: 281-345-5110
email: sales@railking.net
www.railking.net

Frame

Heavy-duty one-piece unitized frame welded from 3" steel plate. Full width bumpers incorporate powertrain protection into design.

Engine

Powered by the industrial off-road Volvo TAD873VE, inline 6-cylinder 7.7-liter Tier 4 final engine with fully integrated and reliable exhaust aftertreatment system. Using SCR technology and a cooled EGR valve reduces complexity and minimizes downtime related to the aftertreatment system. Maximum power and torque are available at low engine rpm. Results are increased power output, lower fuel consumption and reduced noise and engine vibration. Utilizes ultra-low sulfur diesel fuel and DEF (diesel exhaust fluid).

Transmission

Funk DF250 Powershift with torque converter. Four speeds forward and reverse; operator-controlled automatic or manual shift selection. Also, start in second gear feature.

Rail & Road-Drive Axles

Meritor PRC1735 Series heavy duty high torque, outboard planetary axles. Features driver controlled differential lock. Friction road wheel drive transmitted from rail axle incorporates separate braking system. Does not require special tires. Rail shock absorption system with easily replaceable suspension elements is standard.

Brakes

Rail Wheel Axles: Outboard dry-disk brakes.

Road Wheel: disc and caliper, hydraulic actuated on steer axle.

Train Air Brakes: Push button operated to release or fully apply, modulating valve for controlled apply/release, and train air hold feature are standard.

Parking Brake: Enclosed spring applies hydraulically released driveline brake.

Rail Wheels

30" diameter heat-treated cast steel. Bolt on, hardened flange with tapered tread contour.

Road Wheels

16:00 x 25, 28 ply Heavy duty rock lug industrial pneumatic tires.

Pneumatic System

High-capacity 125 cfm air compressor system. Includes two compressors, three reservoirs with drains, water separators and air dryers. Train air flow meter standard.

Couplers

Two weight-transfer couplers made from fabricated steel (no castings). Couplers slide on high-density, self-lubricating nylon bearings for long life and minimal maintenance. This heavy-duty coupler system operates on a center pivot housed in a massive synthetic rubber cushion pressed into both sides of the frame.

Sanders

Large capacity, replaceable steel sandboxes and eight air-operated sanding tubes with easy clean receivers: two for each rail wheel, front and back.

Full-Width Cab

Standard equipment includes new operator self-contained control pod. This command pod is fully adjustable and motorized, offers air ride luxury, and includes all operational controls within arm's reach. The pod is easily moved from left to right as needed to provide excellent direct line of sight visibility down both sides of the railcar when negotiating curves. Pressurized cabin HVAC system, tinted windows, windshield washers, dual jump seats are all standard.

Controls

Single hand joystick controls and full color touchscreen LCD display, multi-color LED rocker switch panels, canbus electrical system with PLC based mobile controller. Allows operators to view real time engine, transmission and Rail King operating parameters, as well as active and stored trouble/diagnostic codes.

Unrivaled Service Access

Maintaining this unit is easy and safe with our exclusive unlimited access feature. The entire platform and cab assembly is mounted on 4 hydraulic cylinders that can raise the assembly up for an additional 18" of clearance to the entire powertrain. Safety lockouts are standard. Remote mounted filters are located for easy and quick services.

Other Features

Air blast 3 trumpet horn, full LED light package, including 4 strobe lights, and Live-View 360-degree 6 camera safety monitoring system with separate monitors in cab.